

Innovator CX

Solid State Transmitter

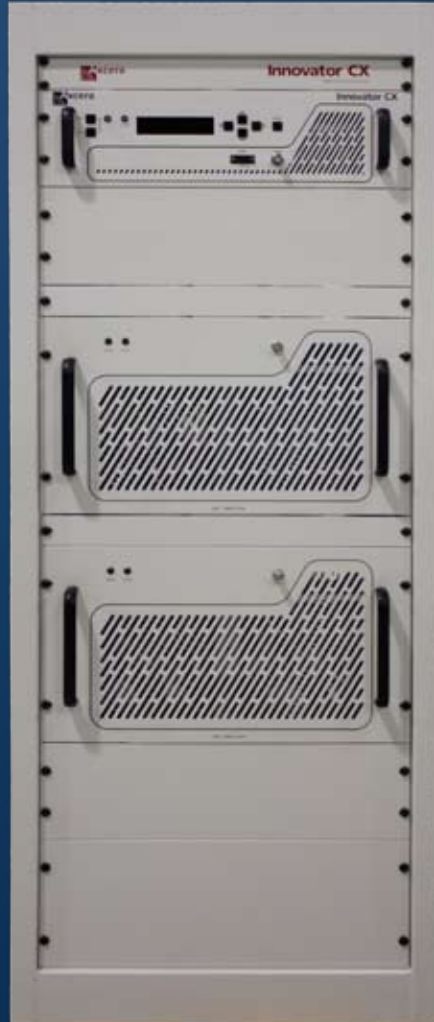



Axcera's Innovator CX series

is a line of feature rich, economical

and compact VHF & UHF

television transmitters and

gap fillers that offer a high level of

performance and reliability.

a t s c

ATSC MOBILE DTV
R E A D Y

DVB

SNMP

ISO9001:2008

Innovator[®] CX Solid State Transmitter

This advanced transmitter line uses our frequency agile exciter and LDMOS transistors for broadband operation across the entire operating band. This allows multi-station owners and networks to minimize spare parts stock, and also enables simple and inexpensive channel changes.

The Innovator CX is available as a transmitter, translator/transposer or low-delay, echo-canceling gap-filler/repeater. The platform supports most any current digital standard, including ATSC, ATSC Mobile DTV, DVB-T/T2/H/SH, ISDB-T/Tb, DAB, T-DMB, CMMB (STiMi) and more. Remote monitoring and control is easily achieved through the available Web browser or SNMP interface.

Like all Axcera products, the Innovator CX is manufactured and supported by our world-class organization under strict ISO 9001:2008 quality control.

Flexible Design and Broad Power Range

All aspects of the Innovator CX design, from frequency range to multi-standard compatibility, reflect Axcera's long-term commitment to broadcasters worldwide. The Innovator CX offers a wide range of modulator and receiver options and power levels, making the Innovator CX perfect for use as a main transmitter, as a gap filler or translator, or for building very efficient single frequency networks (SFNs) using a common transmitter platform. The Innovator CX allows broadcasters to lower both acquisition and operating costs, especially for multi-transmitter operators.

To maximize reliability, the control system, exciter and low power amplifier are completely contained in a single 3RU rack-mount chassis. The external high power amplifier uses parallel transistors to ensure excellent availability. This simple design enhances reliability by reducing component parts count and minimizing harnessing and single point paths, resulting in high MTBF performance. At the same time, the simplicity of the design ensures easy installation and maintenance.

For outdoor installations, the Innovator CX can be integrated into a self-contained, climate-controlled outdoor enclosure, which can include network management system, satellite receiver, synchronization receive equipment, IP input for interface with landline backbone distribution, power conditioning, battery backup system and security system.

Low Power Chassis



The Innovator CX Low Power Chassis houses the modulator or receiver (configuration dependent), low-noise upconverter, RF amplifier, and system controller, all in a compact, 3RU rack-mount package. This chassis serves as a standalone transmitter up to the 100 - 200 watt level (signal dependent), or as the exciter/driver for higher power levels using additional amplifiers. This low power chassis can be configured for analog or digital operation, and as a transmitter, translator/transposer, or gap filler. For full redundancy, a dual exciter option provides a second low power chassis with automatic switching that selects the backup chassis in the unlikely event of a failure.

Digital Modulator

Compliant with Worldwide Standards

This versatile platform is available for most any broadcast standard, including DVB-T/T2/H/SH, CMMB (STiMi), DAB, T-DMB, ISDB-T/Tb, ATSC and ATSC Mobile DTV.

Both linear and nonlinear precorrection is available to ensure optimal system performance. Optional One-Touch Correction (OTC) or adaptive precorrection is also available for most standards.

For single frequency network (SFN) operation, the SFN Support option adds an SFN decoder to detect and process the necessary synchronization and compensation information. All digital settings are stored in non-volatile memory, ensuring that the system will return to normal operation following a power loss.

Analog Exciter-Modulator

Time-Proven Reliability

For analog operation, Axcera's industry-standard analog modulator supports worldwide analog TV standards including systems M, N, B, G, D, K and more. The use of time-proven analog circuitry avoids the possibility of digital artifacts in the picture and provides extremely reliable operation with unequaled stability, performance and signal correction capability.

The modulator corrects the video input signal to ensure proper DC level, and then converts the video and audio signals to a combined, modulated IF output. Non-linear precorrection is applied to ensure excellent intermodulation performance, while linear predistortion corrects for frequency response and group delay errors, resulting in an excellent output signal.

Boosters and Translators/Transposers

Analog and Digital Solutions

Multiple receiver options allow the Innovator CX to operate as an analog or digital translator or a digital on-channel repeater.

Digital receivers allow a much lower signal-to-noise ratio than analog, and most have the ability to recognize and reject multi-path interference. This allows the use of on-channel boosters to fill coverage gaps and even to extend coverage. The Innovator CX can be fitted with a very low delay echo-canceling (LDEC) receiver that simplifies digital booster implementation by canceling system feedback between the transmit and receive antennas. This can reduce the isolation requirements of the booster system by as much as 40dB in some cases. The LDEC repeater also applies non-linear precorrection to compensate for system distortions, ensuring the best possible system performance.

For digital translator/transposer applications, the Innovator CX can be configured with a receiver-demodulator input. This receives the off-air UHF or VHF signal and demodulates it to a baseband bit stream. The bit stream then feeds the Axcera digital modulator/exciter, providing a perfectly regenerated and precorrected digital signal on the desired output channel.

For analog operation, the receiver accepts the off-air UHF or VHF signal and downconverts it to the appropriate visual and aural IF for the given analog system. A surface acoustic wave (SAW) filter rejects adjacent channels and shapes the signal. Precorrection is applied and the signal is upconverted to the desired output channel frequency.

Dual-Cast Functionality

Analog to Digital at the Touch of a Button

With Axcera's exclusive Dual-Cast option, the Innovator CX is configured with both digital and analog modulators, along with an integral switcher. This allows the input to

be switched between analog and digital operation at the touch of a button, both locally and by remote control. As a backup transmitter, Dual-Cast allows a single Innovator CX broadband transmitter to simultaneously back up both a main analog and a main digital transmitter, eliminating the need for separate analog and digital standby transmitters. Dual-Cast allows the Innovator CX to “flash-cut” between analog and digital operation on demand, at the touch of a button.

Upconverter

Low Noise and Frequency Agile

The frequency agile upconverter accepts the standard IF output of the analog or digital modulator and produces on-carrier RF for any UHF TV channel. The very low phase noise synthesized oscillator is fully compliant with international AC106 VALIDATE, as well as ATSC recommendations. The proven frequency agile dual-conversion technology requires no fixed channel filter in its signal path. This allows any channel to be selected directly from the front panel display with no tuning or hardware changes required, enabling a single broadband transmitter to back up multiple channels.

Multiple bandwidths are supported, ranging from 5 to 8 MHz, depending upon the requirements of the selected television standard. The system can be locked to an external 10MHz reference for synchronization or precise frequency offset control. Non-volatile operation is achieved through flash-RAM, which instantaneously stores all digital settings for the entire exciter-modulator system.

Stability is enhanced with an automatic level control (ALC) loop, maintaining consistent performance over environmental variations.

Power Amplifier

Parallel Transistors

The power amplifier section of the Low Power Chassis is available with several different LDMOS amplifier and power supply configurations, allowing it to be used as a final amplifier or as a linear driver for higher power amplifiers. The 3RU rackmount package serves as a complete transmitter for output powers up to 200W. As a linear driver, the amplifier module is configured to provide enough power to drive up to eight Innovator CX higher power amplifier chassis.

In all configurations, a dual-transistor LDMOS amplifier provides excellent linearity, efficiency and reliability, while providing a soft-failure mode to maximize on-air availability. An automatic gain control (AGC) loop is also used to ensure a stable output signal level.

Power Amplifier Chassis

Efficient LDMOS Technology



The Innovator CX is available with up to four high-efficiency LDMOS UHF power amplifiers and up to eight high-efficiency LDMOS VHF power amplifiers for higher power requirements. Each amplifier includes parallel RF paths and parallel power supplies for excellent on-air reliability. Thanks to high-density heat sinks and efficient air-cooling, each PA chassis is capable of output powers reaching 850W average. Multiple power amplifier chassis can be combined for higher power levels.



All high power amplifier stages use parallel transistors to ensure excellent availability. This simple design enhances reliability by reducing component parts count and minimizing harnessing and single point paths, resulting in high MTBF performance. At the same time, the simplicity of the design eases installation and maintenance.

Reliability and availability are also the focus of the PA cooling system design. Each PA uses two cooling fans, configured to draw air from the front of the amplifier and “push” it through the heatsink. This maximizes fan life by ensuring that the fans remain in the cold-air path and operate at a much lower temperature, compared with systems that “pull” heated air through the heatsink and through the fans. This also allows the fans to be easily and quickly replaced from the front of the amplifier while the unit is on the air.

Control & Monitoring

Extensive Local and Remote System Diagnostics



All transmitter control and monitoring functions are available at the exciter through front panel controls, LED status indicators and an informational LCD display. The Axcera-designed in-circuit programmable system controller provides a detailed look into the operation of the transmitter system through a soft-key interface. Parameters such as forward and reflected power, transistor currents, power supply voltages, module temperatures, system mode and much more can be viewed directly from the front of the exciter/driver.

For remote monitoring and control, any Innovator CX can be configured with a Web browser and SNMP communications through an Ethernet (TCP/IP) interface. The Web browser option allows real-time remote control of the transmitter system from any Internet connection and a standard PC with a Web browser, such as Microsoft® Internet Explorer. For continuous monitoring or access through a network operation center, the optional SNMP client provides the ability to communicate with higher-level

network management systems that support simple network management protocol (Get, Set and SNMP traps).

System Protection

High Reliability

To ensure that the Innovator CX Series products will provide reliable service in challenging environments, a high degree of protection is incorporated throughout the system. Overdrive, reflected/VSWR and over-temperature protection are all included within each power amplifier module, and RF shielded circuit enclosures help these products to operate free of interference, even in high RF environments.

Reflected power is also handled at the system level with Axcera's Intelligent VSWR Protection™ (IVP). IVP actually recognizes the cause of VSWR and reacts appropriately in order to protect the entire transmission system while ensuring minimal loss of signal coverage. This unique feature determines whether the high VSWR is caused by a catastrophic problem like a transmission line arc, or if it is the result of a temporary problem such as antenna icing.

In the catastrophic case, a typical transmitter may continue to produce power, resulting in expensive antenna, transmission line or RF system repairs. But with Axcera's IVP, the system is designed to quickly remove drive to the final amplifiers, avoiding further damage to the system components. For a temporary VSWR condition like antenna icing, the system will remain on the air at a reduced power level, ensuring minimal coverage loss during the VSWR condition.

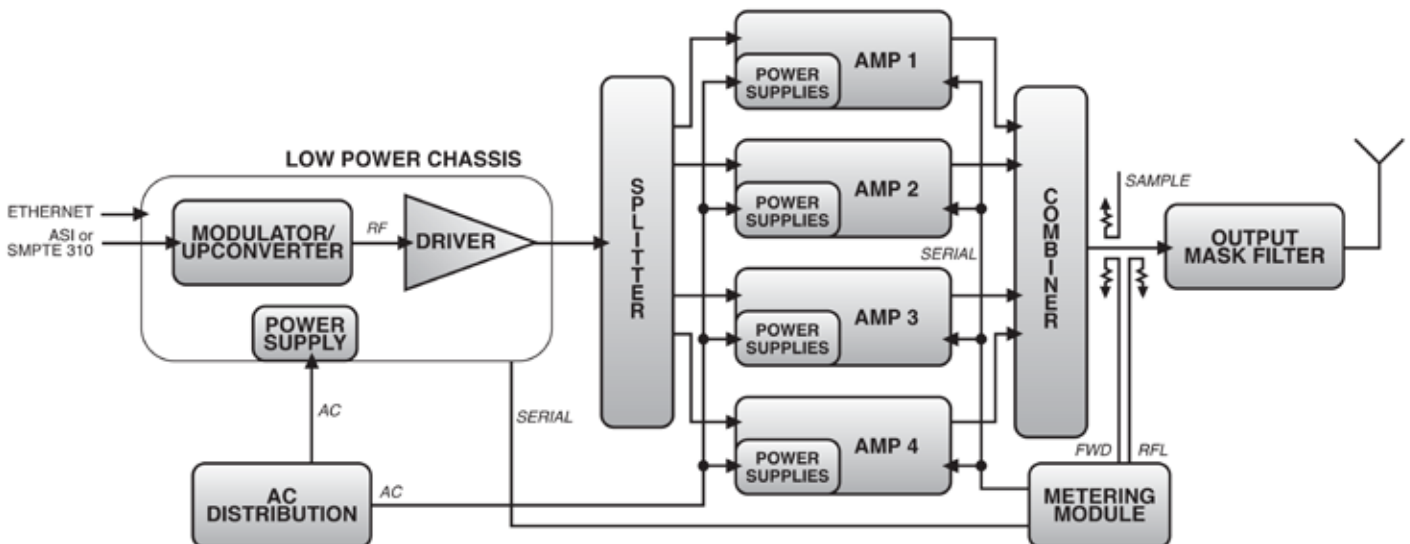

Innovator CX Transmitter System Block Diagram

Features & Benefits

Agile Exciter & Broadband LDMOS Amplifier Modules

The frequency agile exciter and broadband solid-state amplifiers cover the entire operating band, minimizing spare parts stock and simplifying channel changes.

ATSC Digital Modulator

Our fully ATSC compliant 8-VSB modulators include programmable digital equalization, with optional One-Touch Correction or adaptive precorrection, providing excellent SNR performance. Support for advanced modes including Mobile DTV, Distributed Transmission and Bandwidth Enhancement Technology is also available.

Universal Digital Modulator

For worldwide digital standards, Axcera's universal COFDM modulator platform offers digital linear and nonlinear precorrection with optional adaptive mode for a high quality output signal. Supported standards include DVB-T/H, DVB-T2, DVB-SH, ISDB-T/Tb, DAB, T-DMB, CMMB (STiMi), and more.

Protection Circuitry

We have built a high degree of protection into all of our transmitters and exciter systems. Features such as Intelligent VSWR Protection™ and overtemperature and overdrive circuits protect the system from undesirable conditions. Additionally, RF shielded circuit enclosures help our products to operate free of interference even in high RF environments.

Remote Control Capability

Each Innovator CX includes an easily accessible interface designed to work with standard remote control systems, as well as available Web browser and SNMP interfaces.



Innovator CX Configurations



Manufacturing & Support

The Innovator CX transmitter is completely designed, built and factory tested by Axcera under strict ISO 9001:2008 control. This ensures the highest quality manufacturing practices and provides parts and service availability in a very timely fashion, keeping you on the air.

Axcera is serious about our commitment to "Total Customer Happiness." When you choose our products and systems, you will also receive our relentless commitment to your overall satisfaction. Our extensive RF capabilities and experience enable us to provide design and integration services and ongoing customer service and support that are unparalleled in the broadcast industry.

Axcera offers complete RF coverage analysis, system design and integration, installation, project management and support services directly and through our global network of integration and support partners. Our knowledgeable account managers and systems engineers will work with you to ensure that you are provided with a solution that is optimal for your needs. Our world class integration, installation and support team is well recognized in the industry for its exceptional customization capabilities and installation craftsmanship.

Our industry-leading Customer Support Group is a team of experienced field service technicians available 24/7. Our team is also available to travel to your site to quickly resolve any service issues. They are also available for routine maintenance, equipment installation, proof of performance testing and product training.

**Our professional support is available by phone 1-800-215-2614 (North America only)
or +1 724-873-8100 or email: service@axcera.com.**

At Axcera, we look forward to the opportunity to demonstrate our commitment to your total happiness with our products and services.



Axcera, LLC
103 Freedom Drive
Lawrence, Pennsylvania 15055, USA

1-800-215-2614 (North America)
+1 724-873-8100 (International)
+1 724-873-8105 (Fax)

info@axcera.com
www.axcera.com

Specifications published here are current as of the date of publication of this document. Because we are continuously improving our products, Axcera reserves the right to change specifications without prior notice. At any time, you may verify product specifications by contacting our headquarters. Axcera views its patent portfolio as an important corporate asset and vigorously enforces its patents. Products or features contained herein may be covered by one or more U.S. or foreign patents.